

## Precision radial drilling machine with standard chassis and clamping table.

Suitable for machining bulky workpieces

### Facts that impress in terms of quality, performance and price

- ▶ Versatile range of applications
- ▶ Powerful premium motor
- ▶ Electrically braked motor
- ▶ Long reach thanks to horizontally adjustable machine head
- ▶ Mechanical head, column and boom clamping
- ▶ Solid grey cast iron ensures stability, smooth action and precision
- ▶ Spindle with precision taper roller bearings
- ▶ Guaranteed concentricity better than 0.015 mm measured in the drilling spindle sleeve
- ▶ Large speed range from 155 - 2 250 rpm thanks to two-speed motor
- ▶ Solid, precision drilling table, generously dimensioned with precision surface finish and parallel T grooves
- ▶ Thick-walled steel column (Ø 115 mm) ensures smooth action and stability

#### DC control cabinet



> Complet and clear-cut

#### Pull-out shift rod



> Standards-compliant as per DIN 12717

#### Controls



> 24 V DC electrical system



Figure shows optional chuck

## Technical specifications, accessories and dimensions



Model	RD 3
Article no.	3049030
<b>Technical specifications</b>	
Electrical connection	400 V / 3 Ph ~ 50 Hz
Motor output	0.55 / 1.1 kW
<b>Drilling performance</b>	
Drilling performance in steel (S235JR)	Ø 28 mm
Continuous drilling performance in steel (S235JR)	Ø 24 mm
Thread tapping steel (S235JR)	M12
<b>Spindle</b>	
Spindle sleeve stroke	130 mm
Spindle seat	MT 3
Throat	160 - 530 mm
<b>Speeds</b>	
Spindle speeds	155 - 2 250 rpm
Number of speeds	2 x 5 speeds
<b>Drilling table</b>	
Drilling table workspace L x W	780 x 520 mm
Usable workpiece mounting surface	500 x 550 mm
T-slot size / spacing / count	16 mm / 100 mm / 3
Drilling table load bearing capacity	200 kg
Clearance spindle - drilling table	170 - 630 mm
<b>Clamping table</b>	
Length x width x height	280 x 230 x 200 mm
T-slot size / spacing / count	16 mm / 98 mm / 2
Distance spindle to clamping table	max. 430 mm
<b>Dimensions</b>	
Column diameter	Ø 115 mm
Length x width x height	870 x 645 x 1 550 mm (chassis 2 150 mm)
Weight	288 kg

Accessories	Article no.
Quick release chuck direct MT 3/ 1 - 16 mm	3050573
Precision quick release chucks 1 - 8 mm; B16	3050608
Precision quick release chucks 1 - 10 mm; B16	3050610
Precision quick release chucks 1 - 13 mm; B16	3050623
Precision quick release chucks 1 - 16 mm; B16	3050626
Reduction sleeve MT 3 - MT 2	3050663
Morse taper MT 3/B16	3050660
Extension sleeve MT 3 - MT 4	3050668
Twist drill bit HSS / MT 3, 9 parts	3051003
Twist drill bits HSS-CO 5%, 25 parts	3201010
Twist drill bits HSS-CO 5%, 51 parts	3201020
Twist drill bits HSS-CO 5%, 41 parts	3201021
Assortment of clamping tools size 14, 58 parts	3352018
Universal coolant unit	3352002
Thread tapping chuck MT 3 with 6 inserts	3050705
Collet chuck set MT 3/ ER 32 - M12	3352093

› More „Accessories for drills“ from page 64

Machine vices	Article no.
BSI 140	3000214
BSI 200	3000220
BSI-Q 140	3000234
BSI-Q 200	3000240

› Information on the vices on page 71

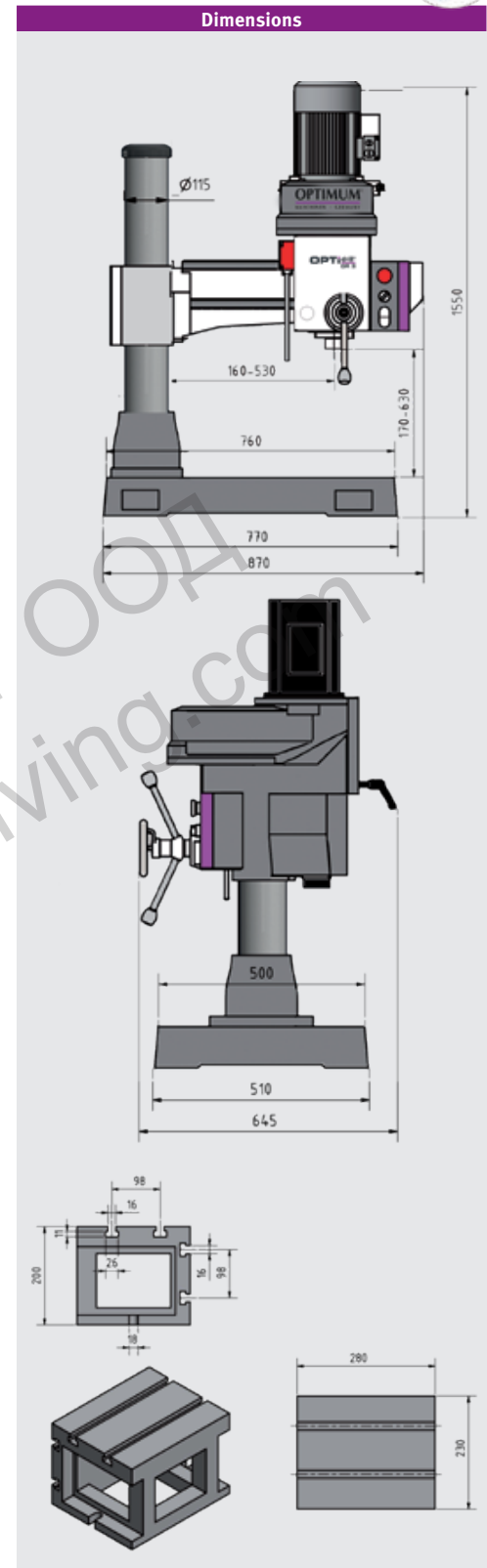

### Scope of supply

- › Machine chassis
- › Clamping table